



# Foundations of Mathematics and Pre-Calculus 10 Examination Booklet 2010 – 2011 Sample A

**DO NOT OPEN ANY EXAMINATION MATERIALS UNTIL INSTRUCTED TO DO SO.**

## Examination Instructions

1. On your Answer Sheet, fill in the bubble (Form A, B, C, D, E, F, G or H) that corresponds to the letter on this Examination Booklet.
2. You may require a protractor and a ruler (metric and imperial).
3. You may use math tiles.
4. When using your calculator (scientific or approved graphing calculator):
  - use the programmed value of  $\pi$  rather than the approximation of 3.14.
  - round only in the final step of the solution.
5. Diagrams are not necessarily drawn to scale.
6. When the examination begins, remove the data pages located in the centre of this booklet.
7. Read the Examination Rules on the back of this booklet.

---

**Contents: 31 pages**

54 multiple-choice questions (maximum of 54 marks)  
6 numeric-response questions (maximum of 6 marks)

**Examination: 2 hours****Additional Time Permitted: 60 minutes**

© Province of British Columbia



**PART A: MULTIPLE-CHOICE QUESTIONS**  
(calculator not permitted)

Value: 12 marks

Suggested Time: 30 minutes  
Allowable Time: 40 minutes

**INSTRUCTIONS:** No calculator may be used for this part of the examination. For each question, select the **best** answer and record your choice on the **blue Answer Sheet** provided. Using an HB pencil, completely fill in the bubble that has the letter corresponding to your answer. You have a **maximum of 40 minutes** to work on this section.

You have **Examination Booklet Form A**. In the box above #1 on your **Answer Sheet**, fill in the bubble as follows.

|                                       |                                  |                       |                       |                       |                       |                       |                       |                       |
|---------------------------------------|----------------------------------|-----------------------|-----------------------|-----------------------|-----------------------|-----------------------|-----------------------|-----------------------|
| Exam Booklet Form/<br>Cahier d'examen | A                                | B                     | C                     | D                     | E                     | F                     | G                     | H                     |
|                                       | <input checked="" type="radio"/> | <input type="radio"/> | <input type="radio"/> | <input type="radio"/> | <input type="radio"/> | <input type="radio"/> | <input type="radio"/> | <input type="radio"/> |

1. Which graph represents the relation  $x - 5y + 10 = 0$  ?

A.

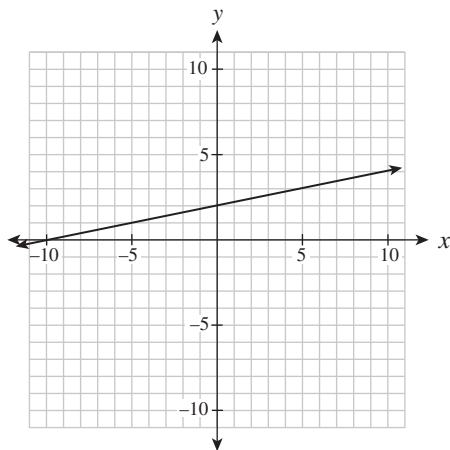

B.

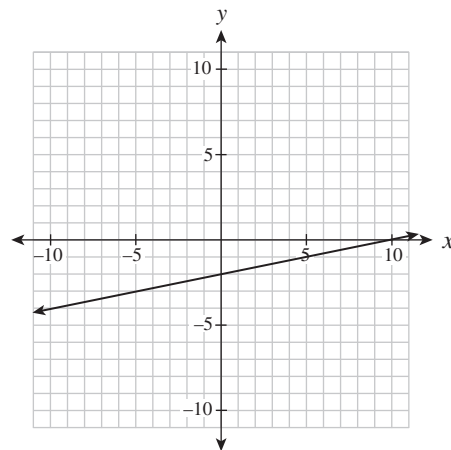

C.

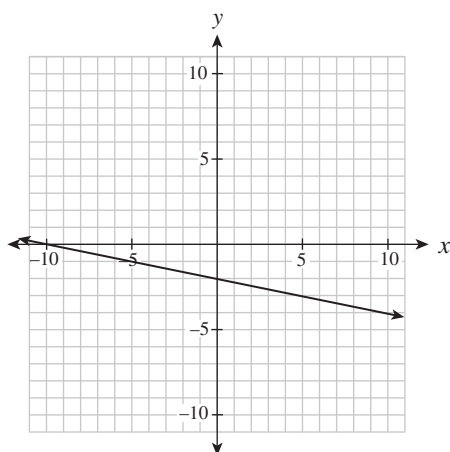

D.

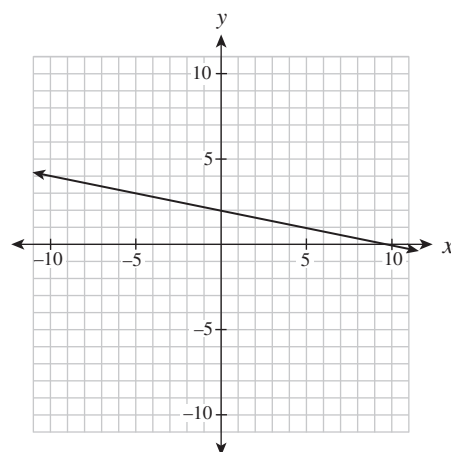

Use the following graph to answer question 2.

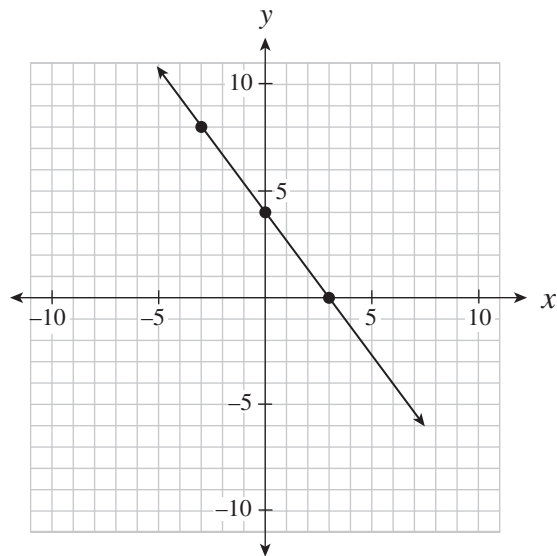

2. Which of the following equations describes the linear relation graphed above?

|      |                               |
|------|-------------------------------|
| I.   | $y = \frac{4}{3}x + 4$        |
| II.  | $y - 8 = -\frac{4}{3}(x + 3)$ |
| III. | $4x + 3y - 12 = 0$            |

- A. II only
  - B. I and II only
  - C. I and III only
  - D. II and III only
- 

3. Determine the equation of a line, in slope-intercept form, that passes through the points (6, 1) and (-10, 9).

- A.  $y = -\frac{1}{2}x + 4$
- B.  $y = -\frac{1}{2}x - 2$
- C.  $y = -2x + 8$
- D.  $y = -2x + 13$

4. Solve for  $y$  in the following system of equations:

$$x - y = -1$$

$$3x + 5y = 21$$

- A. 2
- B. 3
- C. 9
- D. 12

5. The cost  $C$ , in dollars, of renting a hall for the prom is given by the formula  $C(n) = 500 + 4n$ , where  $n$  is the number of students attending the prom. Calculate the cost of renting the hall if 70 students attend.

- A. \$108
- B. \$500
- C. \$780
- D. \$970

6. Which of the following statements are true?

|      |   |
|------|---|
| I.   | $\sqrt{4} = 2$ since $2 \times 2 = 4$               |
| II.  | $\sqrt{8} = 4$ since $4 + 4 = 8$                    |
| III. | $\sqrt[3]{27} = 3$ since $3 \times 3 \times 3 = 27$ |
| IV.  | $\sqrt[3]{81} = 9$ since $9 \times 9 = 81$          |

- A. I and III only
- B. I and IV only
- C. II and III only
- D. II and IV only

7. Which of the following statements are true?

|      |   |
|------|---|
| I.   | The factors of 24 are 2, 3, 4, 6, 8 and 12.         |
| II.  | The prime factorization of 24 is $2^3 \times 3^1$ . |
| III. | The prime factors of 24 are 2 and 3.                |
| IV.  | $\sqrt{24}$ is an irrational number.                |

- A. I and IV only
- B. II and III only
- C. II, III and IV only
- D. I, II, III and IV

8. Simplify:  $\sqrt{72}$

- A.  $2\sqrt{6}$
- B.  $6\sqrt{2}$
- C.  $18\sqrt{2}$
- D.  $36\sqrt{2}$

9. Which pattern could be used to predict  $3^{-4}$ ?

A.

|          |                |
|----------|----------------|
| $3^3$    | 27             |
| $3^2$    | 9              |
| $3^1$    | 3              |
| $3^0$    | 1              |
| $3^{-1}$ | $\frac{1}{3}$  |
| $3^{-2}$ | $\frac{1}{9}$  |
| $3^{-3}$ | $\frac{1}{27}$ |

B.

|          |                |
|----------|----------------|
| $3^3$    | 9              |
| $3^2$    | 6              |
| $3^1$    | 3              |
| $3^0$    | 0              |
| $3^{-1}$ | $-\frac{1}{3}$ |
| $3^{-2}$ | $-\frac{1}{6}$ |
| $3^{-3}$ | $-\frac{1}{9}$ |

C.

|          |     |
|----------|-----|
| $3^3$    | 27  |
| $3^2$    | 9   |
| $3^1$    | 3   |
| $3^0$    | 1   |
| $3^{-1}$ | -3  |
| $3^{-2}$ | -9  |
| $3^{-3}$ | -27 |

D.

|          |    |
|----------|----|
| $3^3$    | 9  |
| $3^2$    | 6  |
| $3^1$    | 3  |
| $3^0$    | 0  |
| $3^{-1}$ | -3 |
| $3^{-2}$ | -6 |
| $3^{-3}$ | -9 |

10. Evaluate:  $16^{-\frac{3}{4}}$

A. -8

B.  $\frac{1}{8}$

C.  $\frac{1}{2}$

D. 2

11. A baker gets his muffin boxes from the United States. The tallest muffins he bakes are 11 cm. Estimate the height of the smallest box in which the muffins will fit.
- A. 30 inches tall
  - B. 10 inches tall
  - C. 5 inches tall
  - D. 4 inches tall
12. Jasdeep and Kelsey converted 177 ounces into kilograms, as shown below.

| Jasdeep's Solution   | Kelsey's Solution   |
|--|---|
| $177 \text{ oz} \times \frac{28.35 \text{ g}}{1 \text{ oz}} \times \frac{1 \text{ kg}}{1000 \text{ g}} = 5 \text{ 017 950 kg}$ | $177 \text{ oz} \times \frac{1 \text{ oz}}{28.35 \text{ g}} \times \frac{1 \text{ kg}}{1000 \text{ g}} = 0.0062 \text{ kg}$ |

Which statement below is true?

- A. Only Kelsey is correct because the units cancel.
- B. Only Jasdeep is correct because the units cancel.
- C. Only Kelsey is incorrect because the conversion factors are incorrect.
- D. They are both incorrect for different reasons.

**This is the end of Part A (calculator not permitted).**

If there is some time left, you have two options:

- i) Make sure you have answered all the questions. You will not be able to go back to this section at the end of 40 minutes.
- ii) You may proceed to the rest of the examination without the use of a calculator; there are many questions that do not require a calculator. Make sure you flag any questions you skip to remember to go back to them later.

Do not access your calculator until directed by the supervisor. At the end of the 40 minutes, the supervisor will give you permission to access your calculator.



**PART B: MULTIPLE-CHOICE QUESTIONS**  
(calculator permitted)

Value: 42 marks

Suggested Time: 75 minutes

**INSTRUCTIONS:** For each question, select the **best** answer and record your choice on the **white Answer Sheet** provided. Using an HB pencil, completely fill in the bubble that has the letter corresponding to your answer.

13. Jim delivers newspapers. He gets paid 10 dollars for every day of work, plus 5 cents for every paper he delivers. Which of the following graphs best represents Jim's possible income for one day?

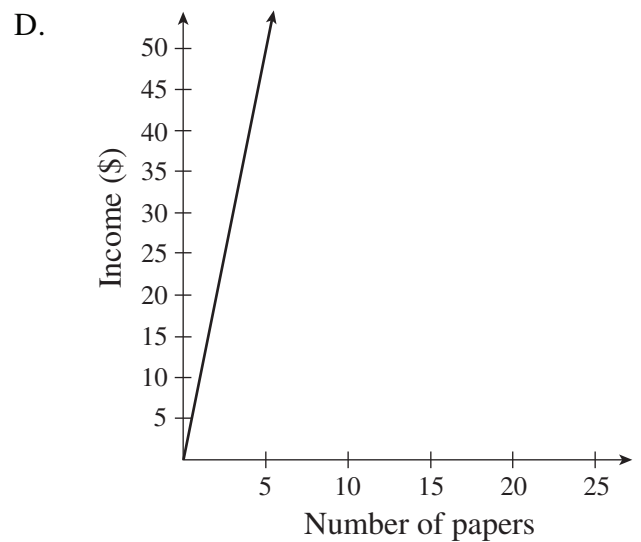
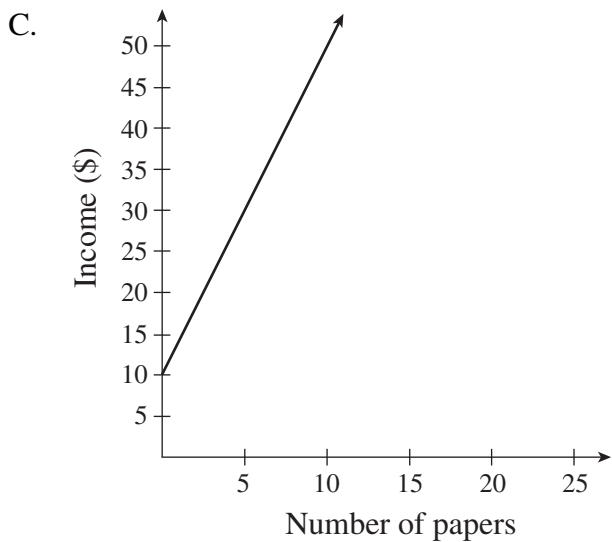
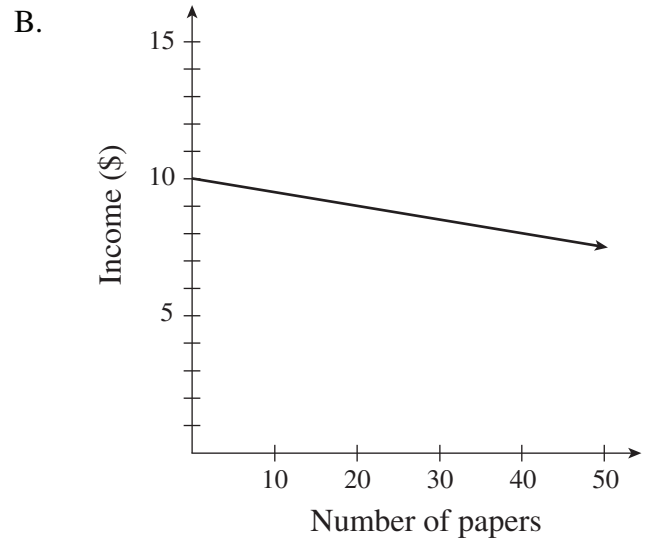
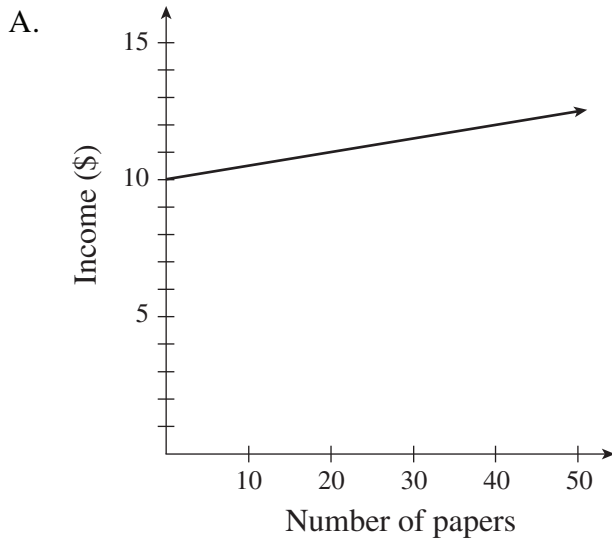

14. Determine the domain of the relation graphed below.

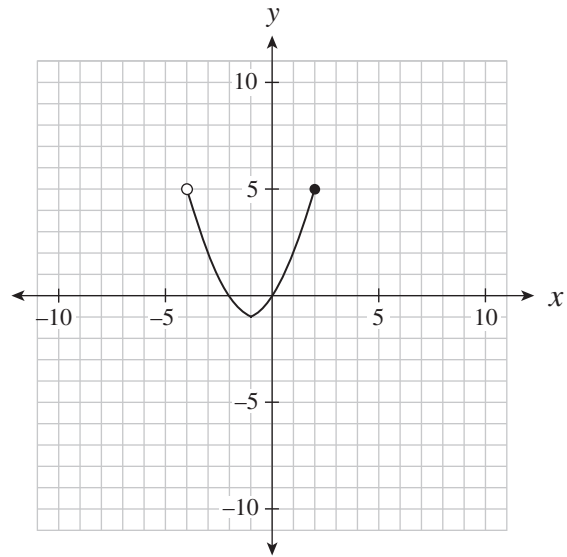

- A.  $(-4, 2]$
- B.  $[-4, 2)$
- C.  $[-1, 5)$
- D.  $[-1, 5]$

15. Which of the following relations are also functions?

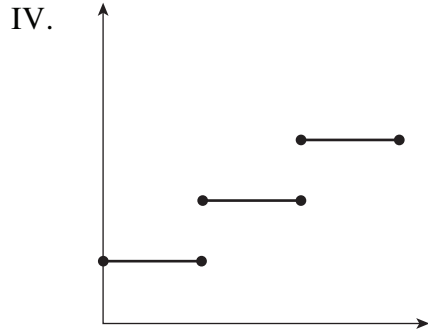
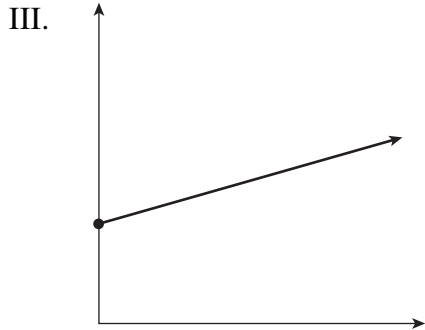
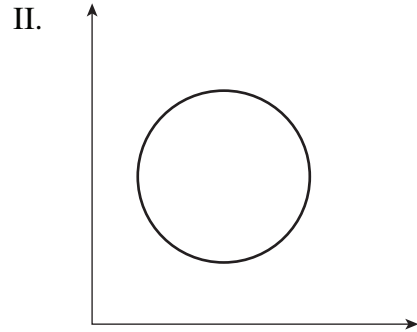
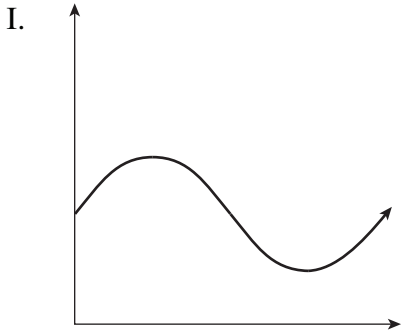

- A. III only
- B. I and III only
- C. II and IV only
- D. I, III and IV only

16. Calculate the slope between the points  $(7, -3)$  and  $(4, 3)$ .

- A.  $-2$
- B.  $-\frac{1}{2}$
- C.  $2$
- D.  $10$

17. Use a ruler to determine the slope of the roof shown below.

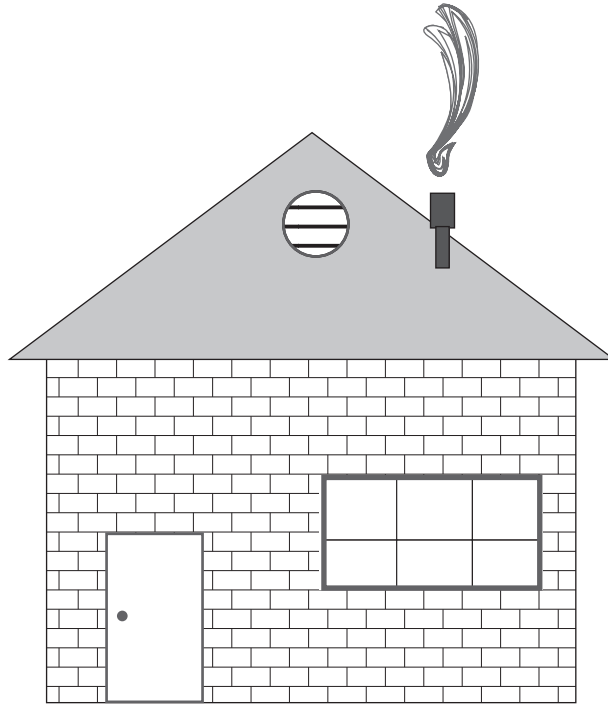

**Note: This diagram is drawn to scale.**

- A.  $\frac{3}{8}$
- B.  $\frac{3}{4}$
- C.  $\frac{4}{5}$
- D.  $\frac{4}{3}$

18. A line with an undefined slope passes through the points  $(-2, 1)$  and  $(p, q)$ . Which of the following points could be  $(p, q)$ ?

- A.  $(1, 0)$
- B.  $(0, 1)$
- C.  $(0, -2)$
- D.  $(-2, 0)$

Use the graph below to answer question 19.

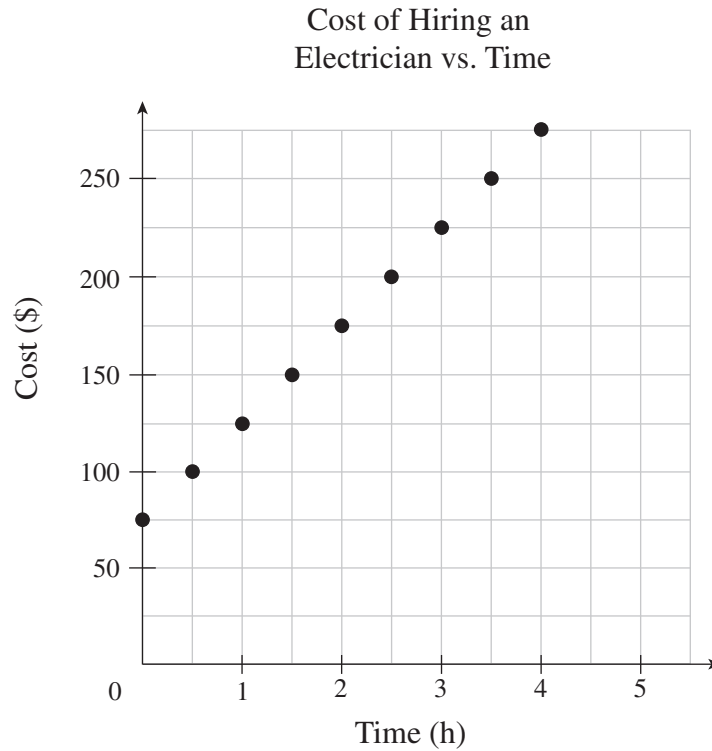

19. What is the cost of hiring an electrician for 8 hours?

- A. \$550
  - B. \$475
  - C. \$400
  - D. \$275
- 

20. Two isosceles triangles have the same height. The slopes of the sides of triangle A are double the slopes of the corresponding sides of triangle B. How do the lengths of their bases compare?

- A. The base of A is quadruple that of B.
- B. The base of A is double that of B.
- C. The base of A is half that of B.
- D. The base of A is one quarter that of B.

21. Which of the following relations could be produced by  $y = \frac{2}{5}x - 6$ ?

|      |   |
|------|---|
| I.   | $2x - 5y - 30 = 0$                            |
| II.  | $\{(15, 0), (10, -2), (-5, -8), (-10, -10)\}$ |
| III. |   |

- A. I only
- B. II only
- C. I and II only
- D. I, II and III

22. Determine the slope of the linear relation  $3x + 5y + 15 = 0$ .

- A.  $\frac{5}{3}$
- B.  $\frac{3}{5}$
- C.  $-\frac{3}{5}$
- D.  $-\frac{5}{3}$

23. Determine the range of the linear relation graphed below.

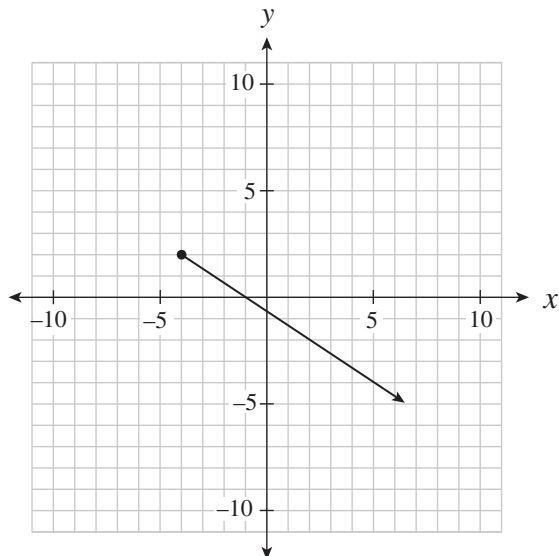

- A.  $y \leq -4$
- B.  $y \leq 2$
- C.  $y \geq -4$
- D.  $y \geq 2$

24. Which of the following coordinates are intercepts of the linear relation  $2x - 3y + 30 = 0$ ?

|      |                    |
|------|--------------------|
| I.   | $(0, 10)$          |
| II.  | $(0, \frac{2}{3})$ |
| III. | $(-10, 0)$         |
| IV.  | $(-15, 0)$         |

- A. I only
- B. I and IV only
- C. II and III only
- D. II and IV only

25. Kelly explained her method for graphing the linear relation  $y = -\frac{2}{3}x + 7$  as follows:

| Steps |  |
|-------|--|
| I.    | Place a dot on the y-axis at positive 7.                                 |
| II.   | Move up two on the y-axis to positive 9.                                 |
| III.  | From the positive 9, move to the left three spots and place a dot there. |
| IV.   | Draw a line through the two dots.  |

Where did Kelly make the first mistake in her explanation?

- A. Step I  
B. Step II  
C. Step III  
D. There is no mistake.
26. Alex bought 144 bagels for \$80. His profit was \$75 once he had sold 100 bagels. Which equation below represents Alex's profit  $P$ , as a function of the number sold,  $n$ ?
- A.  $P = -0.05n + 80$   
B.  $P = 0.05n - 80$   
C.  $P = 0.75n$   
D.  $P = 1.55n - 80$
27. Determine the slope-intercept equation of the line that is parallel to  $y = \frac{2}{5}x - 3$  and passes through the point  $(0, 5)$ .
- A.  $y = -\frac{5}{2}x - 3$   
B.  $y = -\frac{5}{2}x + 5$   
C.  $y = \frac{2}{5}x + 3$   
D.  $y = \frac{2}{5}x + 5$



28. The cost to insure jewellery is a fixed amount plus a percentage of the value of the jewellery. It costs \$32 to insure \$1000 worth of jewellery or \$44.50 to insure \$3500 worth of jewellery. What is the fixed amount to insure jewellery?

- A. \$27.00
- B. \$31.25
- C. \$44.65
- D. \$58.82

29. Lines A and B are perpendicular and have the same  $x$ -intercept. The equation of line A is  $x + 2y - 4 = 0$ . Determine the  $y$ -intercept of line B.

- A.  $-8$
- B.  $-2$
- C.  $4$
- D.  $8$

30. Which of the following systems of linear equations has a solution of  $(-3, 4)$ ?

A. 
$$\begin{cases} 2x - 3y = 6 \\ y = 3x - 13 \end{cases}$$

B. 
$$\begin{cases} 2x - 3y = 6 \\ y = 3x + 13 \end{cases}$$

C. 
$$\begin{cases} 2x + 3y = 6 \\ y = 3x - 13 \end{cases}$$

D. 
$$\begin{cases} 2x + 3y = 6 \\ y = 3x + 13 \end{cases}$$

31. Two planes have a cruising speed of 570 km/h without wind. The first plane flies for 12 hours against a constant headwind. The second plane flies for 10 hours in the opposite direction with the same wind (a tailwind). The second plane flies 370 km less than the first plane.

Determine two equations that could be used to solve for the wind speed,  $w$ , and the distance travelled by the first plane,  $d$ .

- A.  $(570 - w)(12) = d$   
 $(570 + w)(10) = d - 370$
- B.  $(570 - w)(12) = d$   
 $(570 + w)(10) = d + 370$
- C.  $(570 + w)(12) = d$   
 $(570 - w)(10) = d - 370$
- D.  $(570 + w)(12) = d$   
 $(570 - w)(10) = d + 370$

32. Which two numbers have the following properties?

- Their GCF is 12.
- Their LCM is 72.

- A. 2 and 3  
B. 24 and 36  
C. 48 and 72  
D. 72 and 864

33. Polar Company has designed an ice block in the shape of a cube. The volume of the cube is  $15\,625\text{ cm}^3$ . Which of the following dimensions is the smallest opening of an ice dispenser that will accommodate length AB?

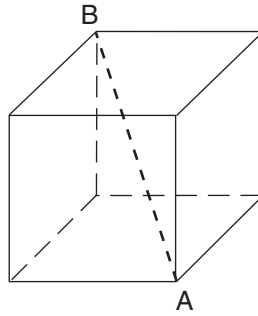

- A. 25 cm wide  
 B. 40 cm wide  
 C. 45 cm wide  
 D. over 50 cm wide
34. Which of the following number lines best represents the placement of X, Y, Z, given:

$$X = 2\sqrt{5}$$

$$Y = \text{cube root of } 68$$

$$Z = \sqrt[4]{2}$$

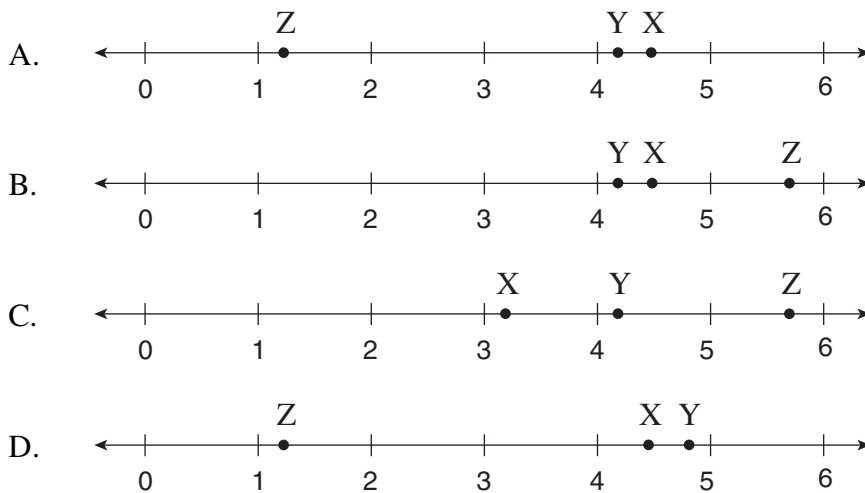

35. Chantal made a mistake in her simplification of  $\frac{(3a^5)^{-2}}{a^4}$ .

| Steps |                               |
|-------|-------------------------------|
| I.    | $\frac{1}{(3a^5)^2(a^4)}$     |
| II.   | $\frac{1}{(3)^2(a^5)^2(a^4)}$ |
| III.  | $\frac{1}{(9)(a^7)(a^4)}$     |
| IV.   | $\frac{1}{9a^{28}}$           |

Which step contains her first mistake?

- A. Step I  
 B. Step II  
 C. Step III  
 D. Step IV
36. Simplify:  $\left(\frac{25x^a}{125x^3}\right)^3$

- A.  $\frac{x^{3a-9}}{125}$   
 B.  $\frac{x^{a-3}}{5}$   
 C.  $125x^{3a-9}$   
 D.  $\frac{x^{27a}}{5}$

37. A research assistant calculated the brain mass,  $b$ , of an 8 kg cat. She used the formula

$$b = 0.01m^{\frac{2}{3}}, \text{ where } m \text{ is the total mass of the cat.}$$

| Steps |                         |
|-------|-------------------------|
| I.    | $b = 0.01\sqrt[3]{8^2}$ |
| II.   | $b = 0.01\sqrt[3]{16}$  |
| III.  | $b \approx 0.01(2.52)$  |
| IV.   | $b \approx 0.025$       |

In which step did the research assistant first make a mistake?

- A. Step I
- B. Step II
- C. Step III
- D. Step IV

38. Which of the following diagrams best represents the expansion of  $(x + 3)(x + 1)$  pictorially?

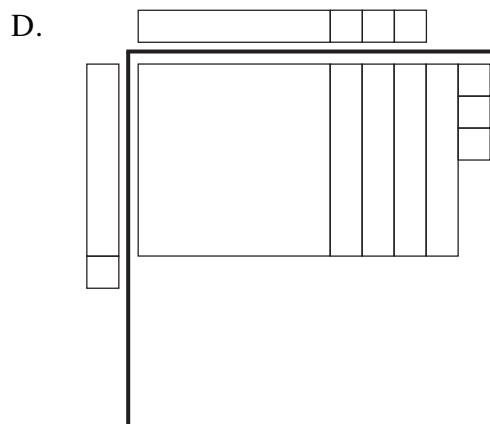
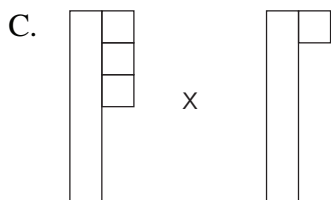
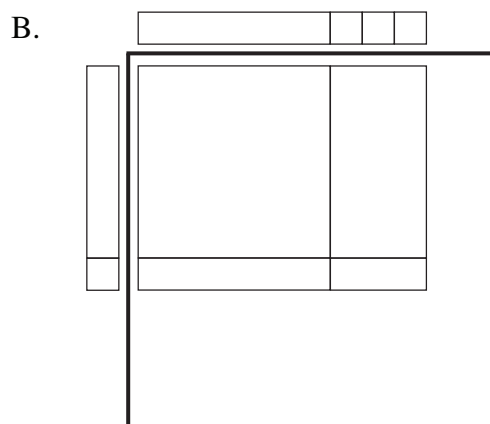
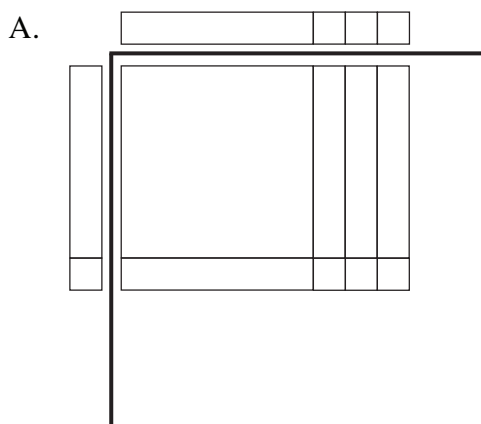

39. Expand and simplify:  $(x - 4)^3$

- A.  $x^3 - 12x^2 + 48x - 64$
- B.  $x^3 + 12x^2 + 48x + 64$
- C.  $x^3 - 4x^2 + 16x + 64$
- D.  $x^3 - 64$

40. Katie simplified the expression  $(x + b)(x + c)$ , where  $b < 0$  and  $c < 0$ , to the form  $x^2 + gx + k$ . What must be true about  $g$  and  $k$ ?

- A.  $g < 0$  and  $k > 0$
- B.  $g < 0$  and  $k < 0$
- C.  $g > 0$  and  $k > 0$
- D.  $g > 0$  and  $k < 0$

41. Factor:  $y^2 - 81$

- A.  $(y - 9)^2$
- B.  $(y + 9)^2$
- C.  $(y + 9)(y - 9)$
- D.  $(y + 3)(y - 3)(y + 9)$

42. Which of the following expressions have a factor of  $x + 2$ ?

|      |                 |
|------|-----------------|
| I.   | $x^2 - 4$       |
| II.  | $2x^2 - x - 10$ |
| III. | $5x + 10$       |

- A. I only
- B. III only
- C. I and III only
- D. I, II and III

43. Given that the area of the rectangle below is  $2x^2 + 9x - 5$ , determine the length of the rectangle.

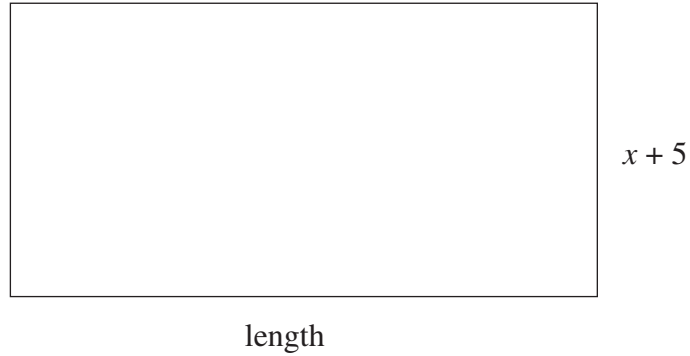

- A.  $2x - 1$   
B.  $2x + 1$   
C.  $2x + 9$   
D.  $2x^2 + 8x - 10$
44. As an estimation strategy, what could be used to best approximate one centimetre?
- A. the length of your foot  
B. the width of your hand  
C. the width of your finger  
D. the width of a pencil lead

45. Sarah needs to replace the exhaust pipe on her dirt bike. She uses a Vernier calliper to find the diameter of the pipe.

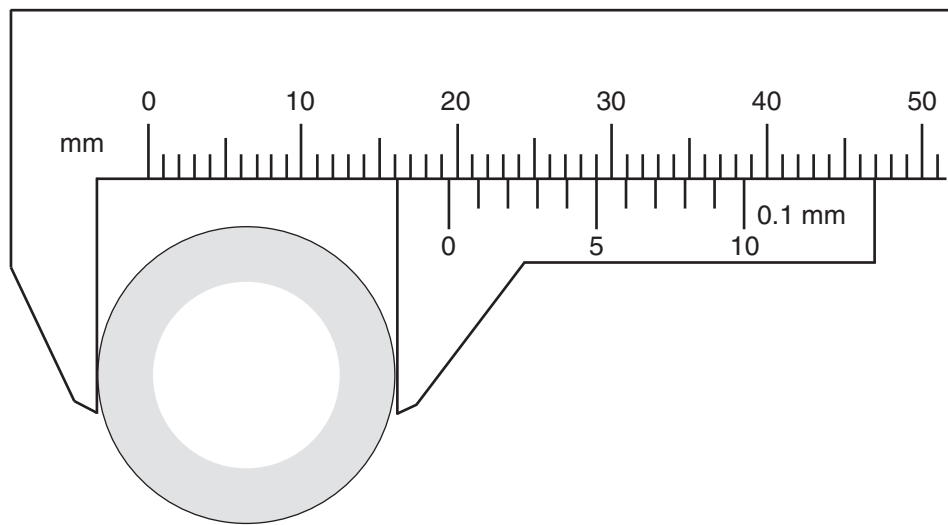

What is the diameter of the pipe?

- A. 16.1 mm  
 B. 19.2 mm  
 C. 19.5 mm  
 D. 29.0 mm
46. On a quiz, students were asked to convert 5 lbs 4 oz to a metric weight.

|        | Stan's Solution  | Erin's Solution  |
|--------|--|--|
| Step 1 | $4 \text{ oz} \times \frac{1 \text{ lb}}{16 \text{ oz}} = 0.25 \text{ lb}$               | $5 \text{ lb} \times \frac{16 \text{ oz}}{1 \text{ lb}} = 80 \text{ oz}$             |
| Step 2 | $5.25 \text{ lb} \times \frac{0.454 \text{ kg}}{1 \text{ lb}} \approx 2.3835 \text{ kg}$ | $84 \text{ oz} \times \frac{28.35 \text{ g}}{1 \text{ oz}} \approx 2381.4 \text{ g}$ |

How should the teacher mark these two solutions?

- A. Only Erin's solution is correct.  
 B. Only Stan's solution is correct.  
 C. Both Stan and Erin gave a correct solution.  
 D. Neither Stan nor Erin gave a correct solution.



47. Which of the following shapes has a volume three times larger than the pyramid below?

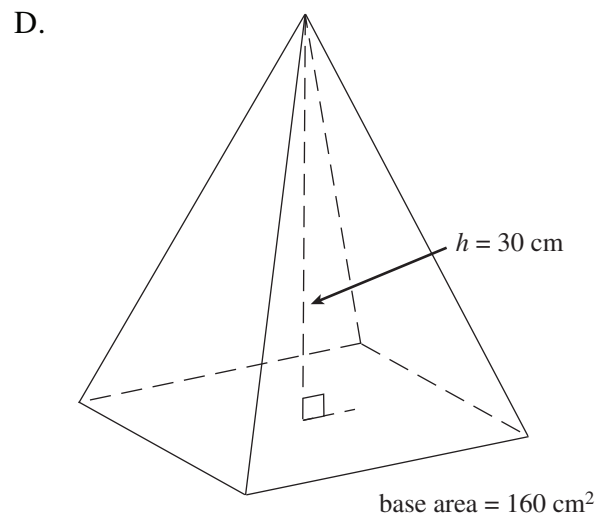
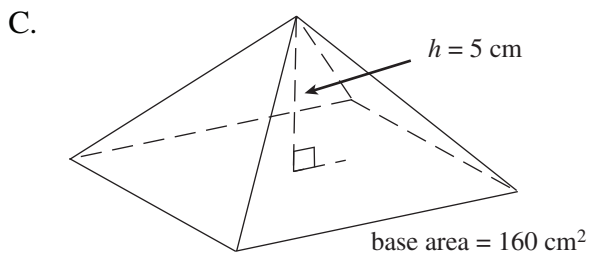
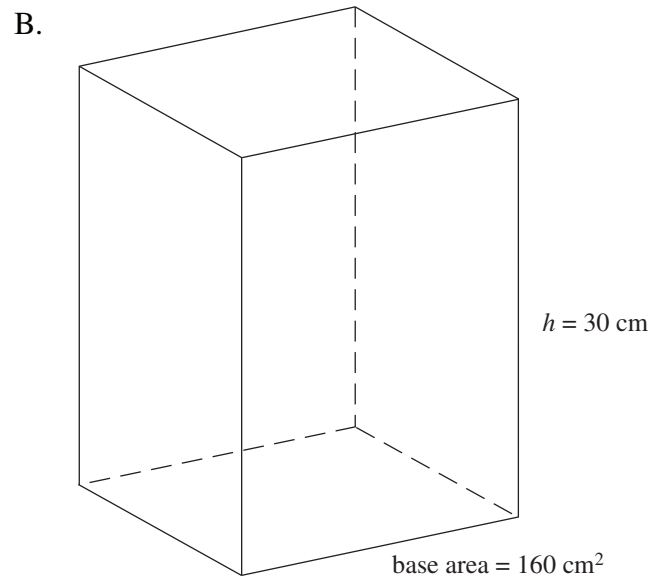
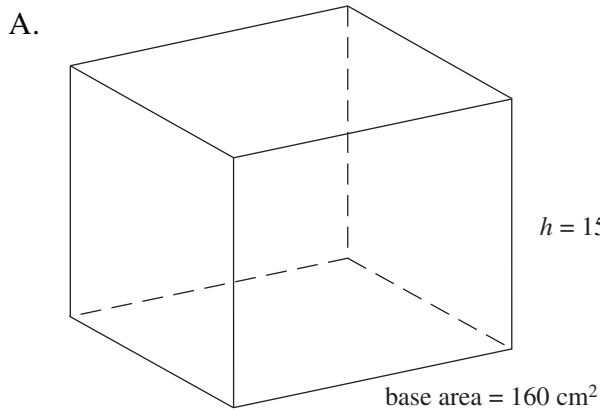
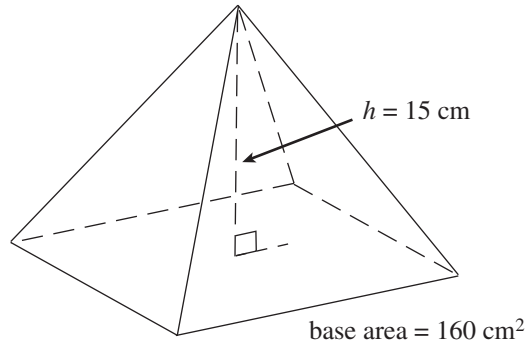

48. A cylinder has a surface area of  $402 \text{ cm}^2$ . The height is three times greater than the radius. What is the height of the cylinder?
- A. 8.00 cm
  - B. 10.48 cm
  - C. 12.00 cm
  - D. 16.97 cm
49. A bowling ball measures 264 cm in circumference. What is the volume of the smallest cube that will hold this ball?
- A. approximately  $75\,000 \text{ cm}^3$
  - B. approximately  $311\,000 \text{ cm}^3$
  - C. approximately  $594\,000 \text{ cm}^3$
  - D. approximately  $2\,300\,000 \text{ cm}^3$

50. Which of the following net diagrams best constructs the cone below?

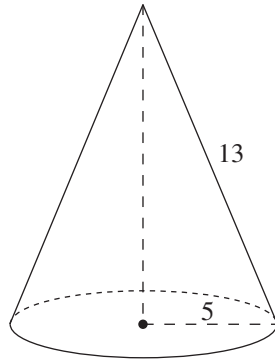

A.

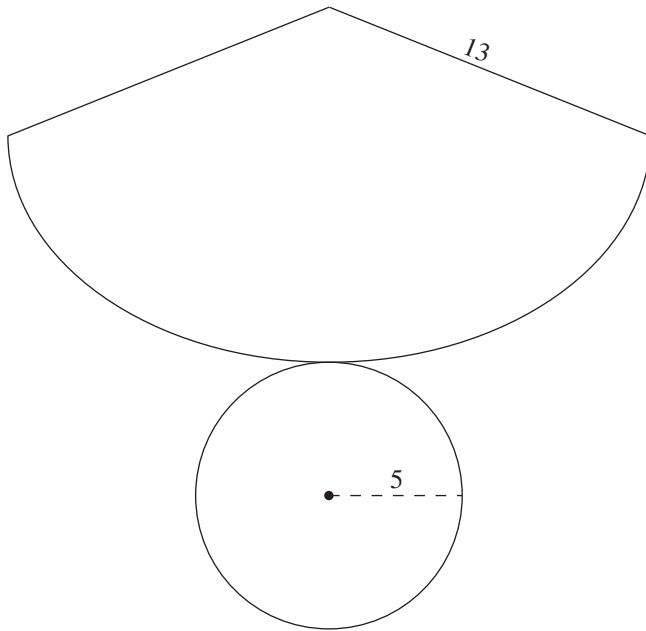

B.

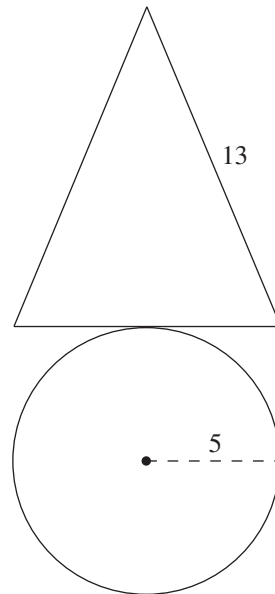

C.

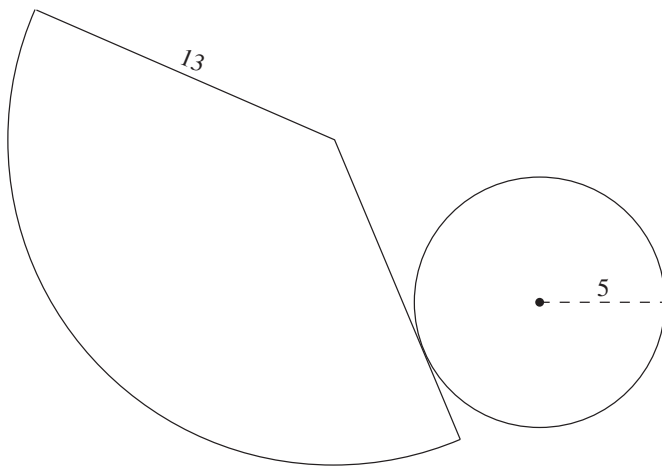

D.

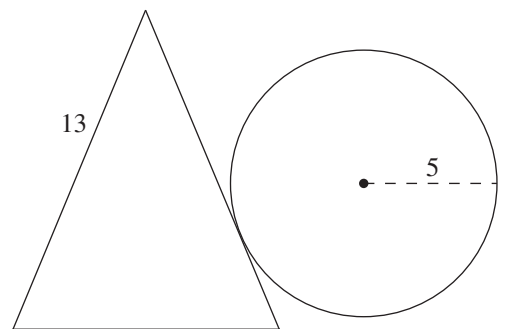

51. Using a protractor, measure one of the unknown angles and determine the length of side  $x$ .

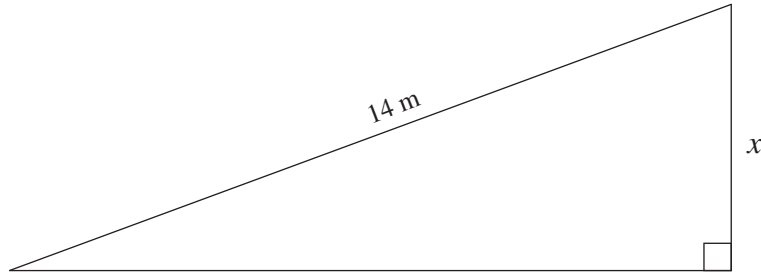

**Note: This diagram is drawn to scale.**

- A. 3.5 m  
B. 4.8 m  
C. 5.1 m  
D. 13.2 m
52. In  $\triangle ABC$ ,  $\angle C = 90^\circ$ ,  $AB = 17$  cm and  $AC = 15$  cm. Calculate the measure of  $\angle ABC$ .
- A.  $28^\circ$   
B.  $41^\circ$   
C.  $49^\circ$   
D.  $62^\circ$
53. A 10 metre tall farmhouse is located 28.0 m away from a tree with an eagle's nest. The angle of elevation from the roof of the farmhouse to the eagle's nest is  $30^\circ$ .

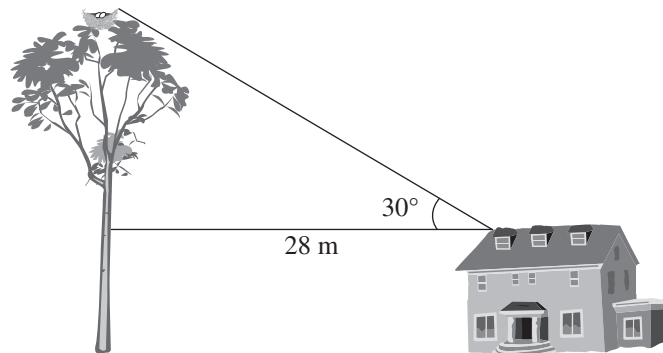

What is the height of the eagle's nest?

- A. 16 m  
B. 24 m  
C. 26 m  
D. 48 m

54. Ann and Byron positioned themselves 35 m apart on one side of a stream. Ann measured the angles, as shown below.

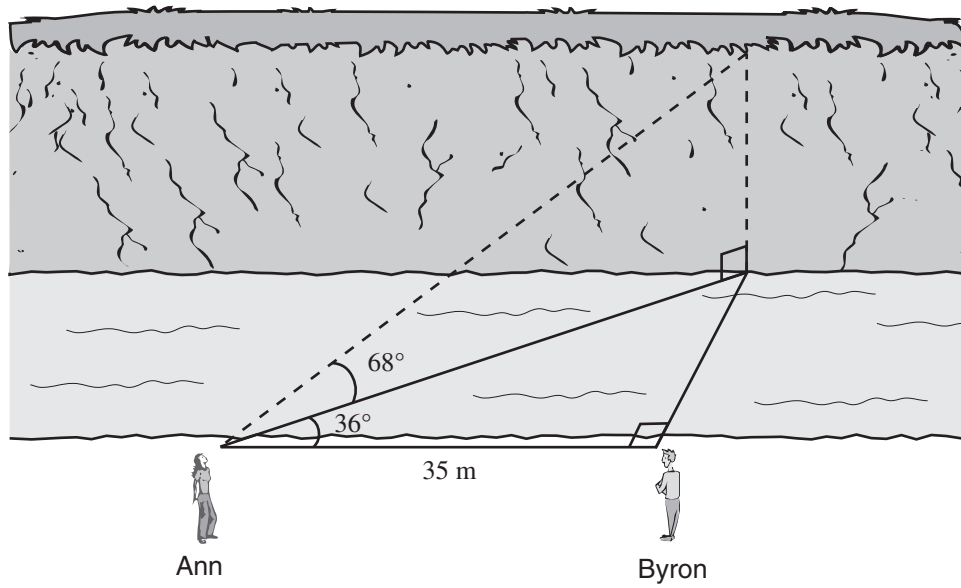

Calculate the height of the cliff on the other side of the stream.

- A. 17.5 m
- B. 62.9 m
- C. 70.1 m
- D. 107.1 m

**PART C: NUMERICAL-RESPONSE QUESTIONS**  
(calculator permitted)

Value: 6 marks

Suggested Time: 15 minutes

**INSTRUCTIONS:** When answering **numerical-response questions** on your Answer Sheet:

- print digits as illustrated:

- shade the bubble with the negative symbol if the answer is negative; shade or leave blank the bubble with the positive symbol if the answer is positive.
- write your answer in the spaces provided using one digit per box, noting proper place value.
- leave unused boxes blank.
- For example,  $-70.2$  will be written as:

$\begin{matrix} + & - \\ \circ & \bullet \end{matrix}$      .

- For example, 4 will be written as:

$\begin{matrix} + & - \\ \circ & \circ \end{matrix}$      .   or  $\begin{matrix} + & - \\ \bullet & \circ \end{matrix}$      .

- For example,  $\frac{2}{3}$ , answered to two decimal places, will be written as:

$\begin{matrix} + & - \\ \circ & \circ \end{matrix}$     .   or  $\begin{matrix} + & - \\ \bullet & \circ \end{matrix}$     .

55. Given the graph of  $y = g(t)$  below, determine the value of  $t$  for which  $g(t) = -3$ .  
Answer as an integer.

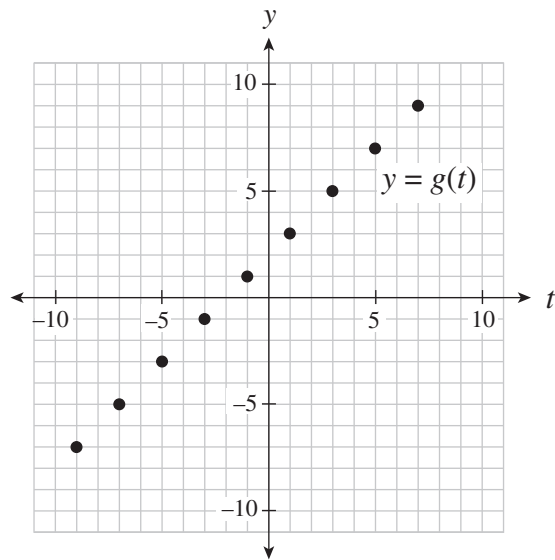

**Record your answer neatly on the Answer Sheet.**

56. Solve for  $x$ :

$$3x + 4y = -16$$

$$x = 4y$$

**Record your answer neatly on the Answer Sheet.**

57. A package of 12 hex bolts and 10 anchor bolts weighs 7 pounds. A second package of 5 hex bolts and 15 anchor bolts weighs 4 pounds. How much does a single hex bolt weigh? Answer in pounds to one decimal place.

**Record your answer neatly on the Answer Sheet.**

58. How many integer values are there for  $k$  for which  $4x^2 + kxy - 9y^2$  is factorable?

**Record your answer neatly on the Answer Sheet.**



59. Convert 150 pounds into kilograms. Answer to the nearest kilogram.

**Record your answer neatly on the Answer Sheet.**

60. A ramp is set up using a rectangular piece of plywood (shaded region) as shown below.

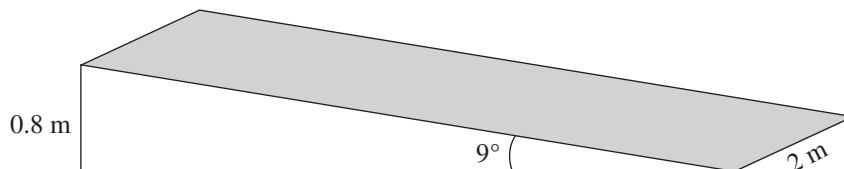

Calculate the area of the plywood. Answer in square metres to one decimal place.

**Record your answer neatly on the Answer Sheet.**

You have **Examination Booklet Form A**. In the box above #1 on your **Answer Sheet**, ensure you filled in the bubble as follows.

|                                       |                                  |                       |                       |                       |                       |                       |                       |                       |
|---------------------------------------|----------------------------------|-----------------------|-----------------------|-----------------------|-----------------------|-----------------------|-----------------------|-----------------------|
| Exam Booklet Form/<br>Cahier d'examen | <input checked="" type="radio"/> | <input type="radio"/> | <input type="radio"/> | <input type="radio"/> | <input type="radio"/> | <input type="radio"/> | <input type="radio"/> | <input type="radio"/> |
|                                       | A                                | B                     | C                     | D                     | E                     | F                     | G                     | H                     |

## Examination Rules

1. The time allotted for this examination is two hours.  
You may, however, take up to 60 minutes of additional time to finish.
2. Answers entered in the Examination Booklet will not be marked.
3. Cheating on an examination will result in a mark of zero. The Ministry of Education considers cheating to have occurred if students break any of the following rules:
  - Students must not be in possession of or have used any secure examination materials prior to the examination session.
  - Students must not communicate with other students during the examination.
  - Students must not give or receive assistance of any kind in answering an examination question during an examination, including allowing their papers to be viewed by others or copying answers from another student's paper.
  - Students must not possess any book, paper or item that might assist in writing an examination, including a dictionary or piece of electronic equipment, that is not specifically authorized for the examination by ministry policy.
  - Students must not copy, plagiarize or present as their own, work done by any other person.
  - Students must immediately follow the invigilator's order to stop writing at the end of the examination time and must not alter an Examination Booklet, Response Booklet or Answer Sheet after the invigilator has asked students to hand in examination papers.
  - Students must not remove any piece of the examination materials from the examination room, including work pages.
4. The use of inappropriate language or content may result in a mark of zero being awarded.
5. Upon completion of the examination, return all examination materials to the supervising invigilator.

## UNIT CONVERSION

|                                       | Common Imperial  | Imperial and SI   | SI  |
|---------------------------------------|--|---|---|
| <b>Length</b>                         | 1 mile = 1760 yards<br>1 mile = 5280 feet<br>1 yard = 3 feet<br>1 yard = 36 inches<br>1 foot = 12 inches | 1 mile $\approx$ 1.609 km<br>1 yard = 0.9144 m<br>1 foot = 30.48 cm<br>1 inch = 2.54 cm | 1 km = 1000 m<br>1 m = 100 cm<br>1 cm = 10 mm   |
| <b>Mass<br/>(Weight)</b>              | 1 ton = 2000 pounds<br>1 pound = 16 ounces   | 2.2 pounds $\approx$ 1 kg<br>1 pound $\approx$ 454 g<br>1 ounce $\approx$ 28.35 g       | 1 t = 1000 kg<br>1 kg = 1000 g  |
| <b>Common<br/>Abbrevia-<br/>tions</b> | mile = mi<br>yard = yd<br>feet = ' or ft<br>inch = " or in<br>ton = tn<br>pound = lb<br>ounce = oz       |   | kilometre = km<br>metre = m<br>centimetre = cm<br>millimetre = mm<br>tonne (metric ton) = t<br>gram = g |

## FORMULAE

|   |        |  |        |        |  |        |  |      |  |      |  |  |  |  |  |      |  |      |
|---|--------|--|--------|--------|--|--------|--|------|--|------|--|--|--|--|--|------|--|------|
| <p>(Put your calculator in Degree Mode)</p> <ul style="list-style-type: none"> <li>Right triangles</li> </ul> $\sin A = \frac{\text{opposite}}{\text{hypotenuse}}$ $\cos A = \frac{\text{adjacent}}{\text{hypotenuse}}$ $\tan A = \frac{\text{opposite}}{\text{adjacent}}$<br><p><b><i>Pythagorean Theorem</i></b></p> $a^2 + b^2 = c^2$<br><p>distance = speed <math>\times</math> time</p>  |        | <ul style="list-style-type: none"> <li>The equation of a line:<br/> <math>y = mx + b</math><br/> <math>Ax + By + C = 0</math><br/> <math>y - y_1 = m(x - x_1)</math> </li> <li>The slope of a line:<br/> <math>m = \frac{\text{rise}}{\text{run}} = \frac{\Delta y}{\Delta x} = \frac{y_2 - y_1}{x_2 - x_1}</math> </li> </ul> |        |        |  |        |  |      |  |      |  |  |  |  |  |      |  |      |
| <b>Math Tiles Legend</b>  |        |  |        |        |  |        |  |      |  |      |  |  |  |  |  |      |  |      |
| <table style="width: 100%; border-collapse: collapse;"> <tbody> <tr> <td style="text-align: center; width: 50%;"></td> <td style="text-align: center; width: 10%;"><math>+x^2</math></td> <td style="text-align: center; width: 50%;"></td> <td style="text-align: center;"><math>-x^2</math></td> </tr> <tr> <td style="text-align: center;"></td> <td style="text-align: center;"><math>+x</math></td> <td style="text-align: center;"></td> <td style="text-align: center;"><math>-x</math></td> </tr> <tr> <td style="text-align: center;"></td> <td></td> <td style="text-align: center;"></td> <td></td> </tr> <tr> <td style="text-align: center;"></td> <td style="text-align: center;"><math>+1</math></td> <td style="text-align: center;"></td> <td style="text-align: center;"><math>-1</math></td> </tr> </tbody> </table> |        |  |        | $+x^2$ |  | $-x^2$ |  | $+x$ |  | $-x$ |  |  |  |  |  | $+1$ |  | $-1$ |
|   | $+x^2$ |  | $-x^2$ |        |  |        |  |      |  |      |  |  |  |  |  |      |  |      |
|   | $+x$   |  | $-x$   |        |  |        |  |      |  |      |  |  |  |  |  |      |  |      |
|   |        |  |        |        |  |        |  |      |  |      |  |  |  |  |  |      |  |      |
|   | $+1$   |  | $-1$   |        |  |        |  |      |  |      |  |  |  |  |  |      |  |      |

## GEOMETRIC FORMULAE

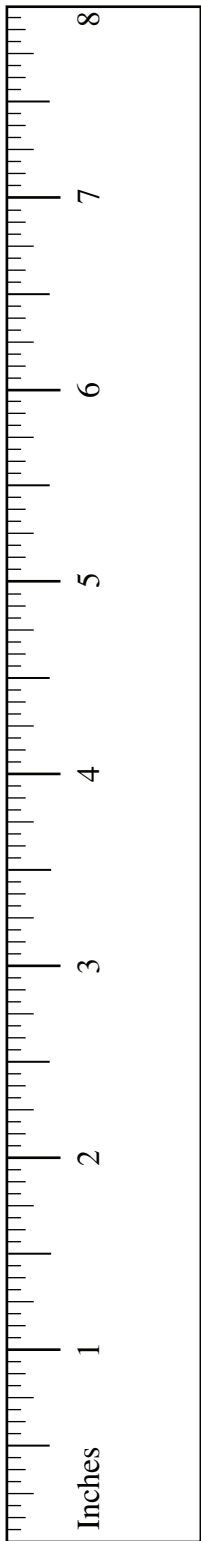

| Key Legend         |                     |
|--------------------|---------------------|
| $l$ = length       | $P$ = perimeter     |
| $w$ = width        | $C$ = circumference |
| $b$ = base         | $A$ = area          |
| $h$ = height       | $SA$ = surface area |
| $s$ = slant height | $V$ = volume        |
| $r$ = radius       |                     |
| $d$ = diameter     |                     |

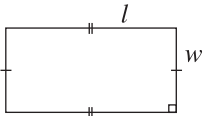
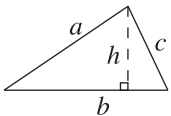
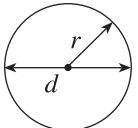
| Geometric Figure  | Perimeter                             | Area               |
|---|---------------------------------------|--------------------|
| Rectangle<br>  | $P = 2l + 2w$<br>or<br>$P = 2(l + w)$ | $A = lw$           |
| Triangle<br> | $P = a + b + c$                       | $A = \frac{bh}{2}$ |
| Circle<br>   | $C = \pi d$<br>or<br>$C = 2\pi r$     | $A = \pi r^2$      |

**NOTE:** Use the value of  $\pi$  programmed in your calculator rather than the approximation of 3.14.

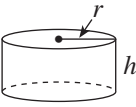
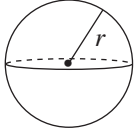
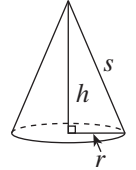
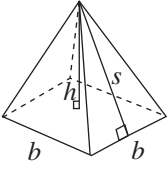
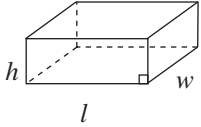
| Geometric Solid   | Surface Area   | Volume  |
|---|--|---|
| Cylinder<br>               | $A_{top} = \pi r^2$<br>$A_{base} = \pi r^2$<br>$A_{side} = 2\pi r h$<br>$SA = 2\pi r^2 + 2\pi r h$ | $V = (\text{area of base}) \times h$                    |
| Sphere<br>                 | $SA = 4\pi r^2$<br><b>or</b><br>$SA = \pi d^2$   | $V = \frac{4}{3} \pi r^3$                               |
| Cone<br>                   | $A_{side} = \pi r s$<br>$A_{base} = \pi r^2$<br>$SA = \pi r^2 + \pi r s$                           | $V = \frac{1}{3} \times (\text{area of base}) \times h$ |
| Square-Based Pyramid<br> | $A_{triangle} = \frac{1}{2} b s$ (for each triangle)<br>$A_{base} = b^2$<br>$SA = 2bs + b^2$       | $V = \frac{1}{3} \times (\text{area of base}) \times h$ |
| Rectangular Prism<br>    | $SA = wh + wh + lw + lw + lh + lh$<br><b>or</b><br>$SA = 2(wh + lw + lh)$                          | $V = (\text{area of base}) \times h$                    |
| General Right Prism   | $SA = \text{the sum of the areas of all the faces}$  | $V = (\text{area of base}) \times h$                    |
| General Right Pyramid   | $SA = \text{the sum of the areas of all the faces}$  | $V = \frac{1}{3} \times (\text{area of base}) \times h$ |

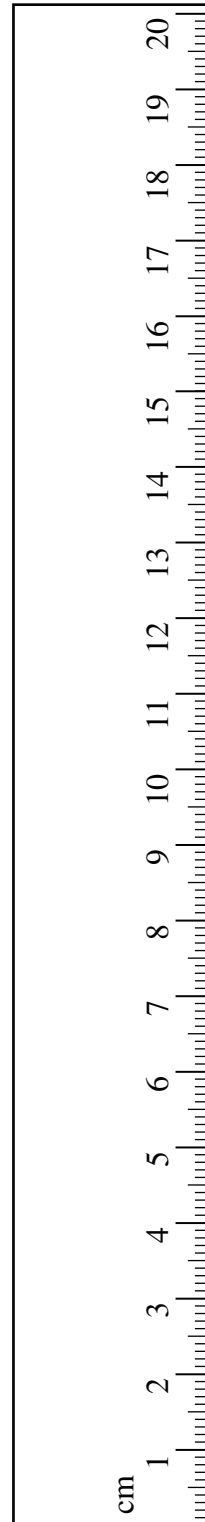

**NOTE:** Use the value of  $\pi$  programmed in your calculator rather than the approximation of 3.14.

**ROUGH WORK SPACE**  
(No marks will be given for work done on this page.)

